

# Largo & Allegro<sup>®</sup>

## Air Compressors

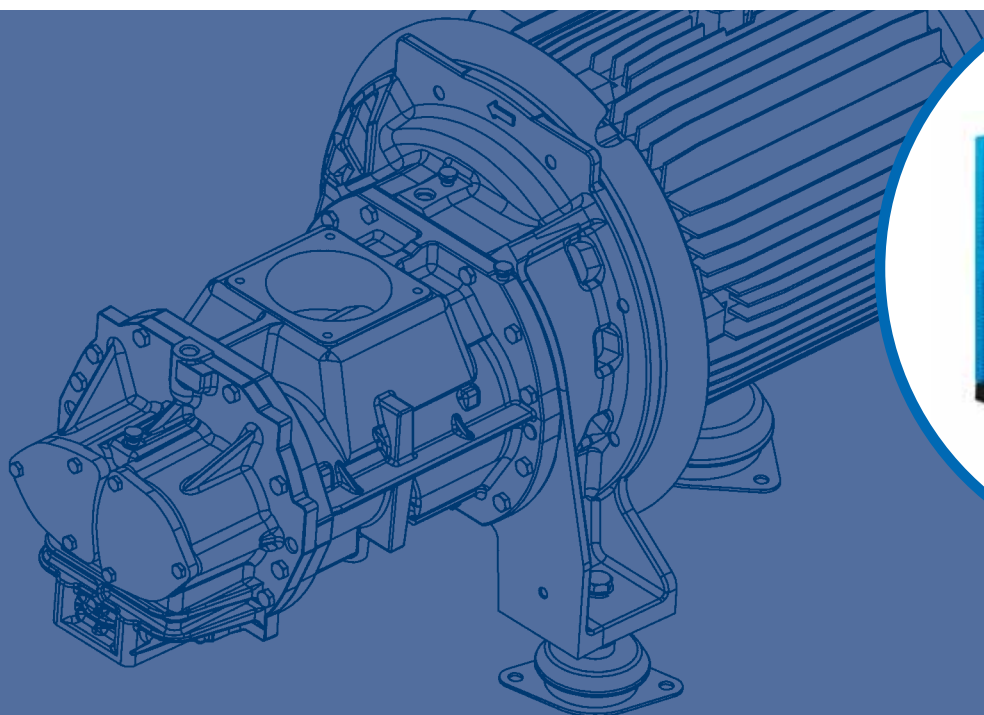

LARGO 110-160 & ALLEGRO 110-180

**ALUP**  
Kompressoren

# ALUP

Driven by technology. Designed by experience.

*ALUP Kompressoren has over 85 years of industrial experience. It is our ambition to offer compressed air solutions that ensure we are first in choice for our customers. To reach this goal we need continuous investment in our product development to make sure that we are always able to offer:*

- High performance and excellent quality
- Integrated engineered solutions
- Full energy efficiency
- Total cost of ownership
- Environmental care

[www.alup.com](http://www.alup.com)



## The power of the Largo & Allegro range

*The Largo 110-160 & Allegro 110-180 range is the most suitable solution for industries looking for peak levels of reliability. The range is the result of continuous improvement and offers significant advantages in minimizing compressor operating costs.*

### State-of-the-art design

- Oil flooded asymmetrical screw type element.
- Most advanced manufacturing equipment to achieve extremely high tolerances.
- Design for higher flow and less energy consumption.



### Reliable and efficient package

- Gearbox driven units with long term reliability and no loss.
- EC turbine fans (except Largo & Allegro 110) for maximum efficiency.
- Selection of high efficient motor.
- Built-in intelligence with the Air Control 4.



## The range that meets all your requirements

*Based on years of experience and including the latest technology, the Largo & Allegro ranges offer the right balance to meet your needs.*

### The reliability you require

- The Largo and Allegro machines ensure a long and trouble free lifetime, even in harsh conditions.
- Via innovative design and selection of high quality components it has been possible to lower compression temperatures and thus increase reliability.

### The simplicity you ask for

- Easy installation: several possibilities for ducting.
- Connections located on the same side.
- Optimized operation: accurate and transparent control from the Air Control 4 controller.
- Simple maintenance: all parts quickly and safely accessible.

### The energy efficiency you need

- The efficiency of our screw element combined with high quality of components enable the Largo and Allegro to achieve higher air flows without increase in power consumption.
- Pressure drop has been minimized through the air flow to ensure the highest efficiency: reducing the generated air pressure by 1 bar will result in energy savings as high as 7% of the power consumed.

### The flexibility you are looking for

- Several models are available, with different pressure variants and cooling variants.
- A large scope of options and solutions to match your precise requirements: filtration panels for dusty environment, integrated water separator for optimum air quality, energy recovery for improved efficiency.



### Energy audit

To optimize your energy efficiency, you need to select the right compressor. Contact your local Alup representative and we will perform a simulation based on your parameters to help you get the perfect compressed air solution.



# Performant package, maximum benefits

*Our products benefit from the latest techniques in research and development to help you achieve the highest productivity.*

High reliability

## Safe and solid air and oil connections

- FLEXMASTER® and VICTAULIC® pipe couplings.
- Increased durability for lower pressure drop and reduced maintenance costs.
- Allow expansion and contraction eliminating risk of air and oil leaks.

## The AIR CONTROL 4 controller

- User-friendly interface with 27 available languages.
- Optimized management of the system pressure.
- Large scope of alarms and safety settings to protect the system.

## Durable transmission

- SUREFLEX® coupling reduces vibrations and extends the life of the airend.
- Reliability is guaranteed for the lifetime of your investment.
- Stress on motor shafts during start up is reduced thanks to the elastic coupling.



Improved efficiency

## Gearbox driven

- Lower energy requirements: none of the losses associated with belt transmissions.
- No maintenance required and no periodic change.

## Improved compression efficiency

- High performance oil lubricated screw element.
- Motor and compressor air intake in a cool zone for reduced motor power consumption.
- High efficiency IP55 motors which comply with the IE2 standard.

## Accurate pressure management

- Accurate pressure transducer and precise pressure band control in the Air Control 4.
- Operates within a minimum pressure band resulting in significant energy savings.



**Efficient cooling module****Advanced turbine technology**

- Designed with one or two EC turbines (with Electronic Commutation motor): rotational speed of the turbine is controlled off the oil temperature (except Largo & Allegro 110).
- Low specific energy requirements and noise level.
- Increased lifetime of the EC turbine due to low stress on the bearings.
- For the Largo & Allegro 110, turbine fan with extremely low rotation speed.

**Large cooling capacity**

- Large surface aluminum type cooler blocks for maximum cooling efficiency.
- Positioned for unobstructed flow of air across the entire cooling surface for maximum temperature reduction.
- Water cooled machines with plated heat exchangers.

**High air quality****Air filtration system**

- Two stage filtration system with 2 $\mu$  high efficiency filter media.
- Protects the internal components and increases their lifetime.
- Encapsulated filter reduces air entry speed and air inlet noise.

**Air/oil separation**

- Air/oil separator and oil filters in warm zone to prevent condensation forming in the oil circuit.
- 3-step separation process for less than 3 ppm residual oil quantity.







Minimum installation cost

### Extremely low noise level

- The epoxy treated canopy is covered with high quality sound attenuating material.
- Noise level compatible with most operating environments for easier installation.

### Low space requirement

- Reduced footprint.
- All-in-one package, no additional equipment needed.
- Connections located at the same side.
- Air inlet and outlet flow allow several installation possibilities.



Maintenance friendly

### Minimum maintenance requirements

- Selection of long lifetime components.
- No regular maintenance of the drive train.
- Air Control 4 service menu calculates the remaining running hours to the next scheduled service.



### Maximum accessibility

- Large opening doors to access all components without extra tooling.
- Quick access to the coolers for cleaning.
- Easy replacement of the oil separator cartridge.



## Variable speed: the most efficient way

The cost of electrical energy has a direct impact on the profitability of your operation and represents about 70% of the total operating cost of your compressor over a 5 year period. That is why reducing the operating cost of a compressed air solution is a major focus. To provide you with the lowest energy cost we have developed high efficiency solutions. The Allegro variable frequency drive compressor can cut the energy bill of your compressor by up to 30%.

Most compressed air requirements vary considerably during the production day. We can produce a comprehensive data log report on the current performance of your air system and demonstrate the potential savings achievable by adopting variable speed technology. These savings can be as much as 30% and can result in a return on investment of less than 2 years.

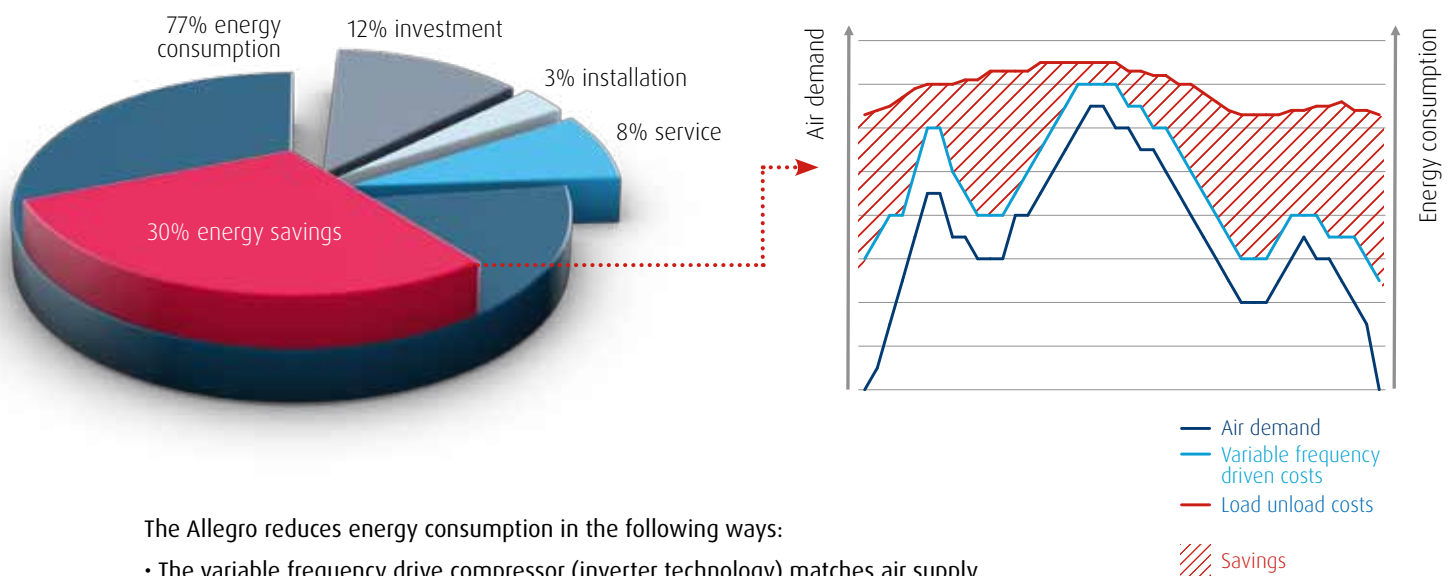

The Allegro reduces energy consumption in the following ways:

- The variable frequency drive compressor (inverter technology) matches air supply with air demand.
- No unload cycles above 20% load.
- No peak current due to soft start. No tax penalties from power suppliers.
- Constant pressure for lower energy consumption and higher process stability.
- Lower maximum pressure and reduced compressed air leaks.

# MAXIMUM ENERGY SAVINGS WITH THE ALLEGRO

## The most effective solution for variable speed

**High efficiency integrated inverter:** Innovations in the field of electronics have led to frequent improvement of components. By using the latest generation inverter, Allegro offers you the most advanced technology.

### **EMC: electro-magnetic compatibility**

An EMC certificate is delivered with all Allegro machines which guarantees that there will be no electromagnetic interference on your system or compressor. EMC conformity is linked to the integration in our compressors of specific components: a cubicle with stringent design, electrical insulators, shielded cables, and most of all an RFI filter (Radio frequency Interference).

### **Reduced footprint**

Being small, the inverter is vertically integrated into the cubicle of a standard Largo canopy. Thus the Allegro has one of the smallest footprints in the market today.

### **IP 55 motor, standard over our range**

Allegro benefits from a high efficiency motor also used on our standard Largo range. This motor is gear driven for improved compressor efficiency and reliability.

### **Accurate and complete monitoring**

Instantaneous motor speed is by default displayed on the screen. Safety messages of the inverter are reported to the controller display for simple diagnosis. And several other functionalities available: many digital inputs/ outputs available, network communication capability, etc.

### **Easy maintenance**

- Standard components.
- Reliable, standard motors and inverter.
- Worldwide customer service available everywhere.
- Additional filtration panel as standard to protect the system.

## Several models and variants

- Allegro 110, 132 and 180.
- Covering a pressure delivery band of 4 to 9.5 bar or 7 to 12.5 bar in the High Pressure variant.
- Variable speed compressor as air- or water-cooled.



## Recover the energy of your compressor

*When air is compressed, heat is formed. The excess heat can be captured with an energy recovery option and channelled to other applications allowing you to save energy and cut costs.*

### Reduce your energy bill

Energy is created by the compressor in the form of heat. This energy can be recuperated in different ways usable for industrial applications, such as: space heating, pre-heating feed water for steam boilers, etc.

The benefit is not only the reduction in carbon dioxide emissions, but also the reduction in the total plant energy cost. The energy which is generated by the compressor must not be generated by a separate energy source!

### Heating with warm air

The warmed compressor cooling air can be used to heat up your premises: with a simple ducting, the warm air can be directed to where it is needed (workshops, warehouses, etc.). This solution allows to recover up to 95% of the energy input of the compressor.

### Heat exchanger system

The energy recovery option integrates a built-in heat exchanger on the oil circuit, which heats up the continuously pressurized water flow. The system is thermostatically controlled and the performance of the compressor is not influenced at any time.

The energy recovery option is a simple and very compact mechanical system that requires no maintenance or electricity consumption, but offers you significant reductions in your energy costs.

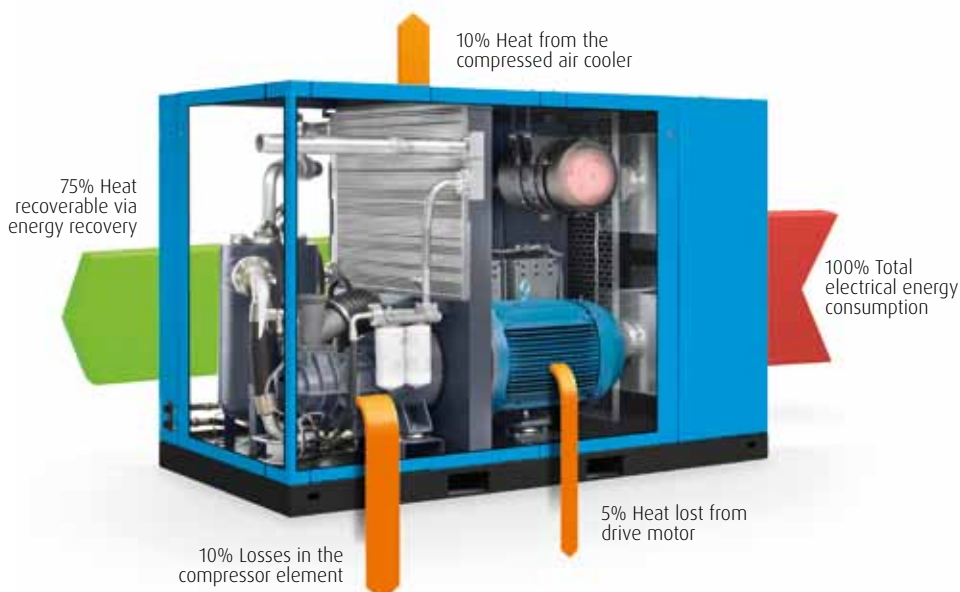

# A large range of options for total flexibility

Whether you are faced with harsh ambient conditions, strict environmental or safety requirements, specific air quality requirements, or cost reduction through energy recovery, the Largo and Allegro ranges have the solution.



## Harsh ambient conditions

- High efficiency air intake filter.

## Energy efficiency

- Energy recovery: recover a lot of the energy generated by the compressor, which can be used to heat up water for showers, boilers, etc.

## Integrated filtration and treatment

- Water separator: reduces up to 90% of the condensate in the compressed air.
- Automatic drain: ensures no air loss during condensate removal (only in combination with internal water separator).



## Lubricant and servicing

- 4000h oil.
- 8000h oil.
- Food grade oil.

## Electronic

- Phase sequence relay: control the rotation direction of the electrical phases of the unit.
- Modulating control: adjust the compressor flow rate using very slight pressure variations in the operating network.
- Communication options of Air Control 4.



# Technical specifications

## Fixed Speed

Model	Max. working pressure		Reference working pressure		Free Air Delivery at reference conditions*			Motor power		Noise level**	Cooling air volume	Weight	Compressed air output diameter
	bar	psi	bar	psi	m³/h	l/s	cfm	kW	hp	dB(A)	m³/h	kg	"
<b>Largo 110</b>	7.5	109	7	106	1175	326	692	110	150	75	15000	1810	2"
	8	116	7.5	109	1139	316	670	110	150	75	15000	1810	2"
	10	145	9.5	142	1025	285	603	110	150	75	15000	1810	2"
	13	203	12.5	200	880	244	518	110	150	75	15000	1790	2"
<b>Largo 111</b>	7.5	109	7	106	1192	331	702	110	150	75	19500	2931	3"
	8	116	7.5	109	1143	317	673	110	150	75	19500	2931	3"
	10	145	9.5	142	1028	285	605	110	150	75	19500	2931	3"
	13	203	12.5	200	866	240	510	110	150	75	19500	2931	3"
<b>Largo 132</b>	7.5	109	7	106	1415	392	833	132	180	75	19500	3020	3"
	8	116	7.5	109	1358	377	799	132	180	75	19500	3020	3"
	10	145	9.5	142	1231	341	725	132	180	75	19500	3020	3"
	13	203	12.5	200	1011	280	595	132	180	75	19500	3020	3"
<b>Largo 160</b>	7.5	109	7	106	1717	477	1011	160	220	73	26000	2830	3"
	8	116	7.5	109	1641	456	966	160	220	73	26000	2830	3"
	10	145	9.5	142	1490	414	877	160	220	73	26000	2830	3"
	13	203	12.5	200	1231	342	725	160	220	73	26000	2830	3"

## Variable Speed

Model	Working pressure	Min. Free Air Delivery (4 bar)		Max. Free Air Delivery *												Motor power		Noise Level **	Cooling air volume	Weight	Compressed air output diameter		
		bar	m³/h	l/s	cfm	7			9.5			10			12.5			kW	hp	dB(A)	m³/h	kg	"
						m³/h	l/s	cfm	m³/h	l/s	cfm	m³/h	l/s	cfm	m³/h	l/s	cfm						
<b>Allegro 110</b>	4-10	202	56	119	1144	318	673	1019	283	600	n.a	n.a	n.a	n.a	n.a	n.a	110	150	75	15000	1860	3"	
	4-13	142	39	84	902	251	531	897	249	528	895	249	527	883	245	520	110	150	75	15000	1860	3"	
<b>Allegro 132</b>	5-10	310	86	183	1486	412	872	1360	377	798	n.a	n.a	n.a	n.a	n.a	n.a	132	180	75	19440	2509	3"	
	5-13	375	104	221	1291	358	758	1234	342	724	1230	341	722	1183	328	694	132	180	75	19440	2509	3"	
<b>Allegro 180</b>	4-10	276	77	162	1820	506	1071	1615	449	950	n.a	n.a	n.a	n.a	n.a	n.a	180	240	73	26000	3550	3"	
	4-13	283	79	167	1361	378	801	1349	375	792	1341	373	789	1315	365	774	180	240	73	26000	3550	3"	

\* Unit performance measured according to ISO 1217, Annex C, 1996.  
 \*\* Noise level measured according to ISO 2151.  
 All technical data for air-cooled machines, 50 Hz.  
 For technical data of water-cooled machines or 60 Hz machines, please contact your local sales force.

## Dimensions

### Fixed Speed

Model	Length		Width		Height	
	mm	inch	mm	inch	mm	inch
<b>Largo 110</b>	2160	85.0	1100	43.3	1600	63.0
<b>Largo 111</b>	2860	112.6	1500	59.0	1940	76.4
<b>Largo 132</b>	2860	112.6	1500	59.0	1940	76.4
<b>Largo 160</b>	2842	112.0	1610	63.4	1992	78.4

### Inverter Driven

Model	Length		Width		Height	
	mm	inch	mm	inch	mm	inch
<b>Allegro 110</b>	2160	85.0	1060	41.7	1600	63.0
<b>Allegro 132</b>	2860	112.6	1500	59.0	1940	76.4
<b>Allegro 180</b>	2942	115.8	1610	63.4	1992	78.4





**DRIVEN BY TECHNOLOGY DESIGNED BY EXPERIENCE**



**CONTACT YOUR LOCAL  
ALUP  
REPRESENTATIVE**

**Your authorized distributor**

6999640290

[www.alup.com](http://www.alup.com)